

MDD

Manual Test Stand

- 220 lbf (1 kN) capacity
- Robust design
- High precision
- Compact & portable
- Handwheel operation
- Tension & compression



- Rugged & reliable
- Holes for bench mounting
- Accepts digital height scales

Shown with digital force gauge
(not supplied)

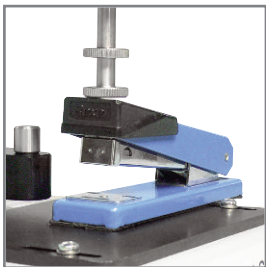

Actuation testing

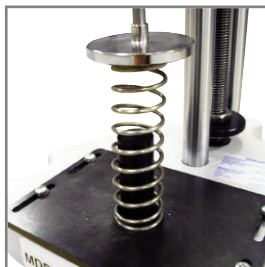

Spring testing

The MDD, combined with a Mecmesin force gauge, is ideal for low-cost tensile and compression testing on the production floor or in laboratories.

Easy to use, the MDD is operated via a handwheel, which gives precise control of the crosshead, together with a lockable thumbwheel for fine adjustment.

The MDD is also fitted with a standard dovetail bracket for easy interchangeability of Mecmesin force gauges and loadcells. An optional height scale can be added for digital display of displacement and optional feet allow the MDD to be used horizontally.

versatile
easy-to-use
cost-effective

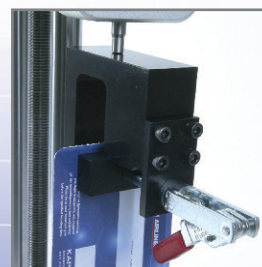

Tear testing



Tensile testing

Dimensions inch (mm)

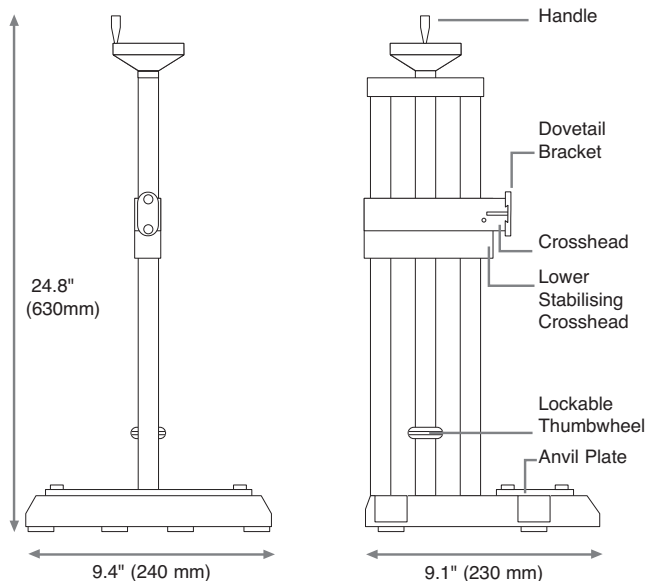

Optional Extras

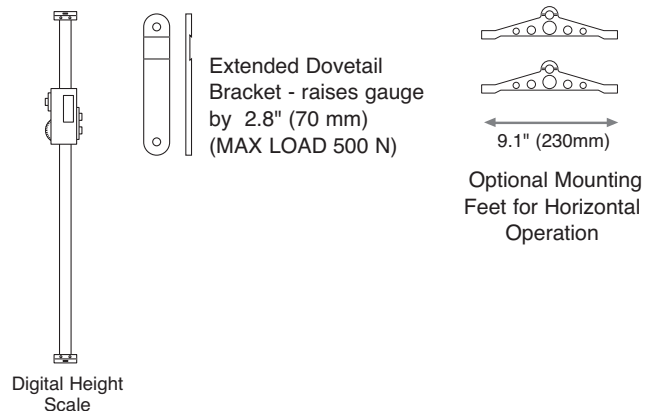

Specifications

Model	MDD - Manual Direct Drive Test Stand
Crosshead travel (both directions)	0.1" (2 mm) per handwheel revolution
Effective crosshead travel height	15.7" (400 mm) with AFG force gauge without accessories 15.7" (400 mm) with BFG force gauge without accessories 15" (380 mm) with AFG/BFG force gauges and height scale without accessories
Maximum Load	220 lbf/1000 N/100 kgf
Weight	13 lb (6 kg)
Optional Extras	
Height scale	0.0005" (0.01 mm) resolution
Mounting feet	For horizontal operation

Mecmesin reserves the right to alter equipment specifications without prior notice

North America

Mecmesin Corporation

45921 Maries Road, Suite 120,
Sterling, Virginia 20166, U.S.A

e: info@mecmesincorp.com

t: 703 433 9247 f: 703 444 9860

www.mecmesincorp.com

datasheet ref: 431-002-03-L01